

ASSEMBLY INSTRUCTIONS

1012-T & 1213-T

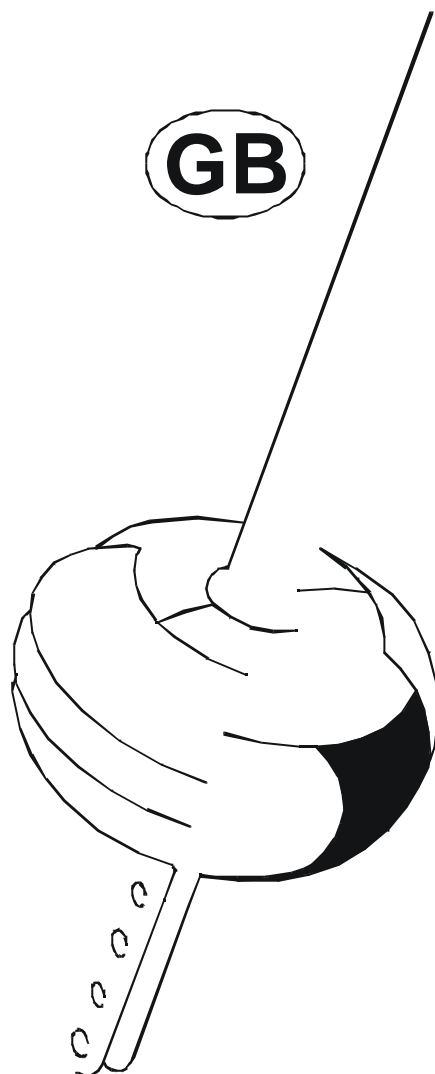

JIB REEFING 1012-T & 1213-T

Thank you for buying a Plastimo product. Your Universail headsail reefing system was designed and manufactured by Plastimo with the utmost care and we trust that you will be rewarded with years of smooth and reliable operation.

The new 1012-T and 1213-T jib reefing systems are the result of our long experience and know-how.

Our new systems are strong, efficient, easy and quick to install, thanks to the particular choice of materials and design.

We guarantee our products five years.

PLASTIMO, 15 rue Ingénieur Verrière, B.P. 435, 56325 LORIENT CEDEX (FRANCE)
Téléphone : 02 97 87 36 36 - Télécopie : 02 97 87 36 49
<http://www.plastimo.com>

1 - TECHNICAL CHARACTERISTICS	3-4
2 - DESCRIPTION OF THE VARIOUS SUB-UNITS	5-6
3 - TOOLS NEEDED	7
4 - DISMANTLING THE FORESTAY	8
4A) Lower part	
4B) Higher part	
5 - ASSEMBLING THE DRUM TUBE	9
5A) Installing the two chainplates	
5B) Installing the drum tube	
6 - FITTING THE DRUM ON THE FORESTAY.....	10
6A) For assembly on forestay with eye	
6B) For assembly on forestay with turnbuckle	
7 - ASSEMBLY OF LOWER SPAR.....	11
8 - ASSEMBLY OF INTERMEDIARY SPARS.....	12
9 - ASSEMBLY OF LAST SPAR.....	12
10 -FITTING THE SPAR END	13
11 - INSTALLING THE HALYARD DIVERTER (OPTION).....	14
12 - INSTALLING THE JIB REEFING	15
13 - INSTALLING THE DRUM REEFING LINE	16
14 - WHEN USING AS HEADFOIL	17
15 - FIXING THE BOLT ROPE FEEDER.....	17
16 - RAISING THE SAIL.....	17
17 - USEFUL ADVICE	18-19
18 - MAINTENANCE	20
19 - OPTIONS.....	21
20 - SPARE PARTS	22-23

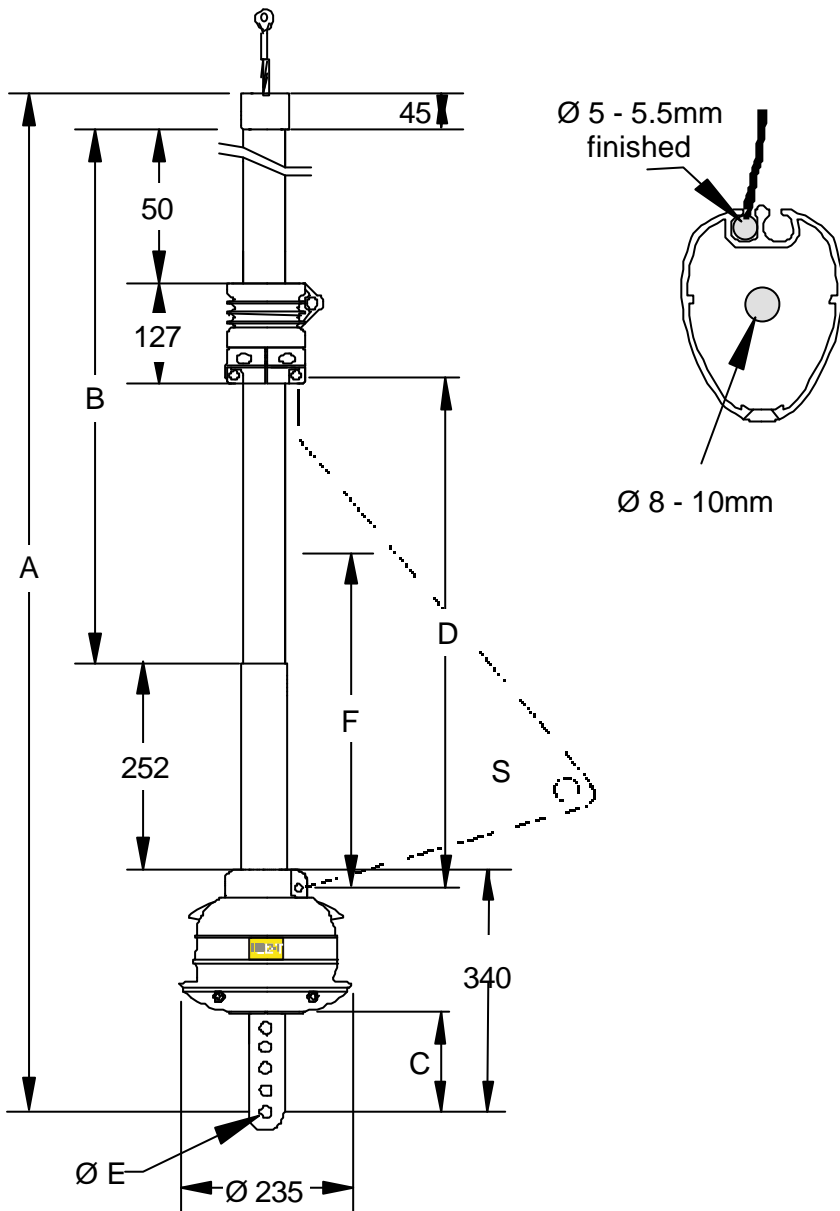

Model	1012-T	1213-T
Reference	31204	31449
Ø Forestay (mm)	8 – 10	8 – 10
Ø Bolt rope (mm)	5 - 5.5	5 - 5.5
Dim. A (m)	14.50	16.50
Dim. B (m)	13.9	15.9
Dim. C (mm)	180	195
Dim. D (m)	14	16
S (m ²)	50	50
Ø E (mm)	14.5	14.5
Balls	Torlon ®	Torlon ®
Dim F (m)	1	1
Connections	Delrin ® + Aluminium + screw	Delrin ® + Aluminium + screw
Number of grooves	2	2

2 – DESCRIPTION OF THE SUB-UNITS

- 1 drum unit



- 1 drum tube l=300mm

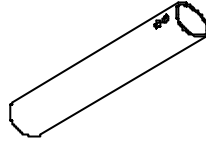

- 2 chainplates

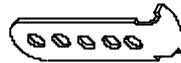

- 1 halyard swivel

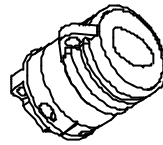

- 1 spar end



- 6 black connecting sleeves (10-12 T); 7 for (12-13 T)

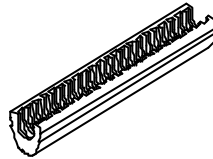

- 2 blue connecting sleeves



- 8 connecting stops (10-12 T); 9 for (12-13 T)

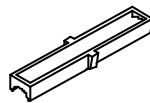

- 7 aluminium « stop-rotation » connections (10-12 T); 8 for (12-13 T)

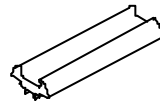

- 1 aluminium lower spar connection

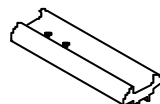

- 1 bolt rope feeder

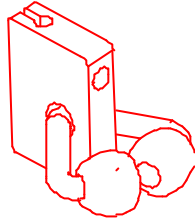

- 1 lower spar

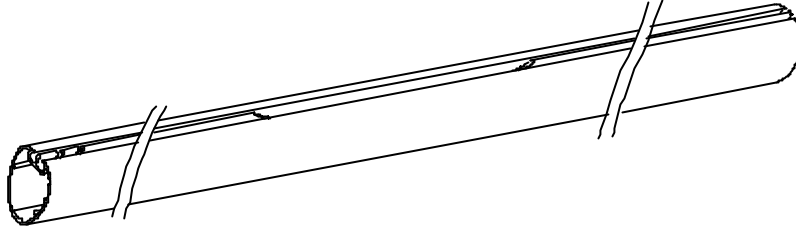

- 6 intermediary spars

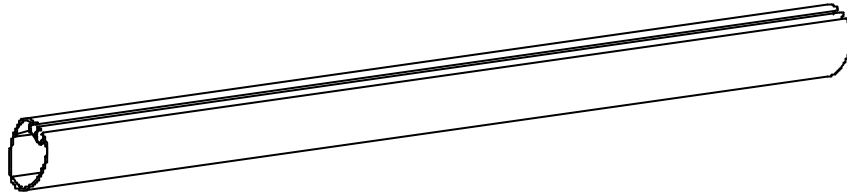

- 25 cross-headed screws $\varnothing 3.9 \times 15.9$ (10-12 T) for spar connections (+ 1 extra screw)
- 29 + 1 for (10-12 T)



- 1 cross-headed screw $\varnothing 4.8 \times 12.7$ (for top end stop)

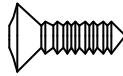

- 2 screws CHC M6x20 (for drum tube/drum)

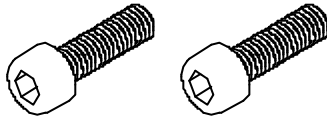

- 2 screws CHC M6x16 (for lower spar/drum tube)

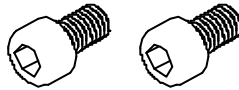

- 2 nuts $\varnothing 10 \times 6$ haut. 10mm (for lower spar/drum tube)



- 1 screw + nut M14 (1012-T) or M16 (1213-T)

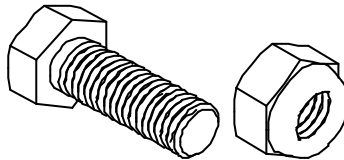

3 - TOOLS YOU WILL NEED

- 1 cross-headed screwdriver N°2
- 1 metric allen key set
- 1 hacksaw
- 1 two-meter measuring tape
- 1 comfortable Bosun's chair (Plastimo).
- 1 plier (multi-position)
- 1 hammer
- 1 drill
- 1 drill bit Ø4.2
- 1 drill bit Ø2.8
- neutral mastic silicon.

4 - TAKING DOWN THE FORESTAY

4A) LOWER PART

- Slacken the backstay.
- Secure the mast forward with one or two halyards (or releasable forestay).
- Stretch the halyards to relieve the strain on the forestay.
- Take down the lower part of the forestay (this is usually done by removing a clevis pin and a split pin, or a screw and a nut).

Note : It is important to check the position of the eye of the forestay in relation to the attachment point at the bow of the boat in order to be able to adjust it as before.

Where a turnbuckle is used, measure the distance between the mounting plate and the nut that blocks the turnbuckle.

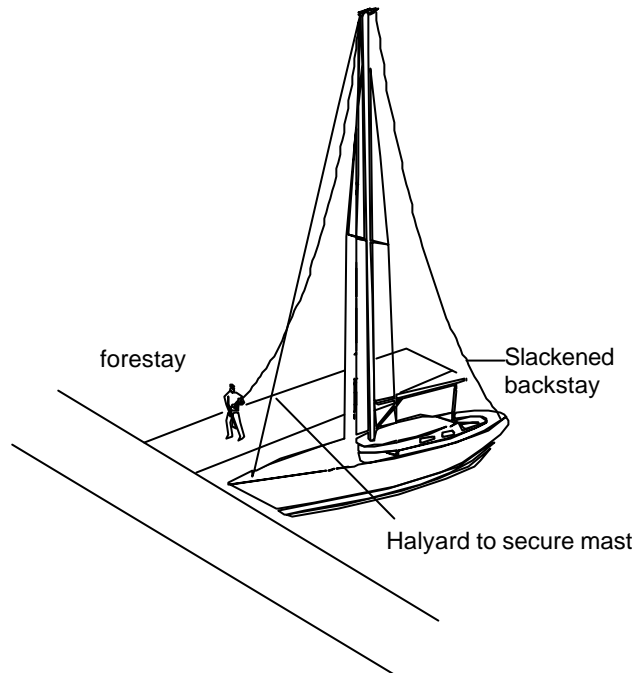

4B) HIGHER PART

- Send a person, equipped with hammer and pliers, up to the masthead.
(take the necessary precautionary measures to avoid any risk of accident)
- Take down the upper part of the forestay.
- Bring the person and the forestay down from the masthead.

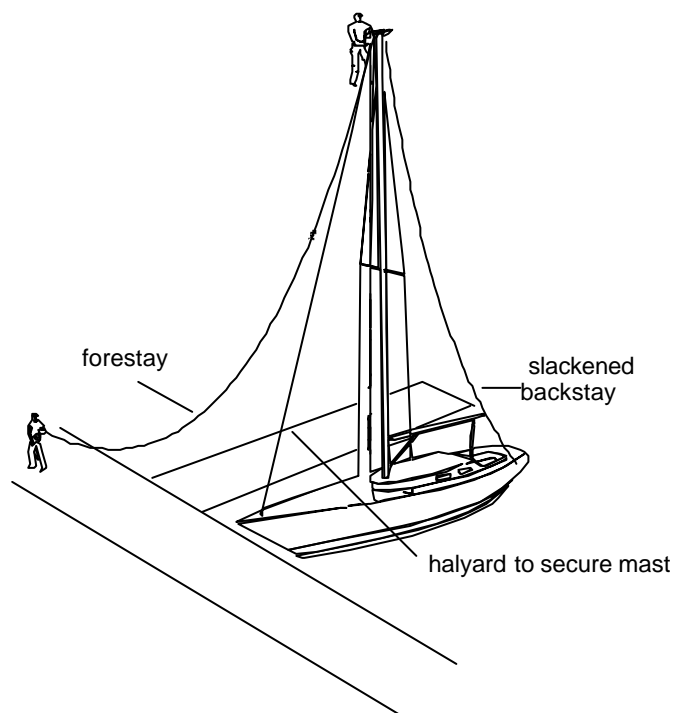

5 - INSTALLING THE DRUM

5A) HOW TO PUT THE TWO CHAINPLATES TOGETHER

- The chain plates have spurs which maintain them in position inside the drum ; screws are therefore not needed.

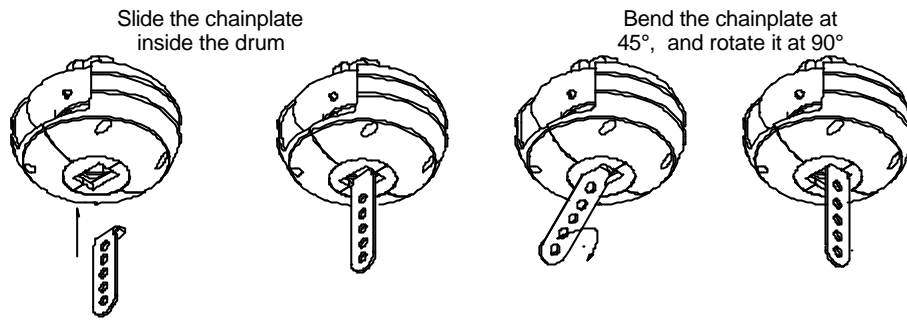

Repeat operation for the second chain plate

5B) INSTALLING THE DRUM TUBE

- Fit the drum tube on the drum with the two screws CHC M6x20 (put mastic silicone on the screws)

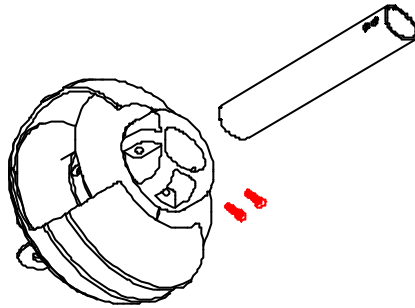

- Lie the forestay flat on the pontoon

- Place the various items beside the forestay

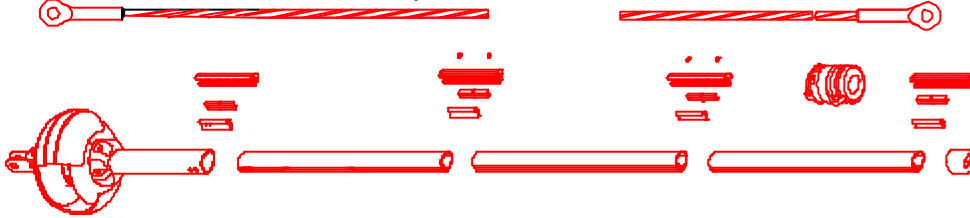

6 - INSTALLING THE DRUM ON THE FORESTAY

6A) HOW TO INSTALL THE DRUM ON A FORESTAY WITH EYE

You can fit the forestay directly onto the chainplates but it is advisable to use a toggle.

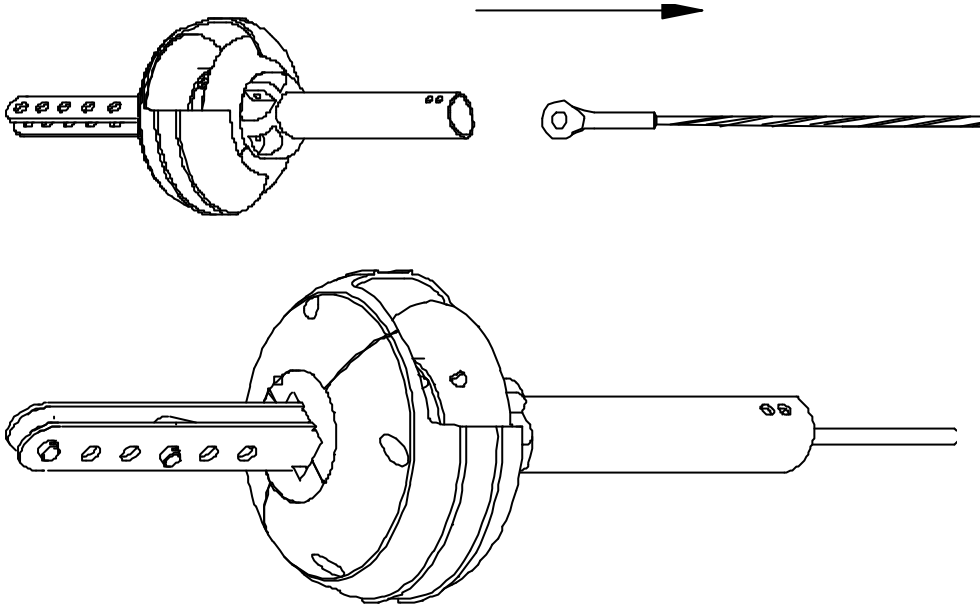

You can also choose to install the drum with a toggle, which will make the whole unit easier to manipulate.
(Plastimo toggle as option : Ref:30531)

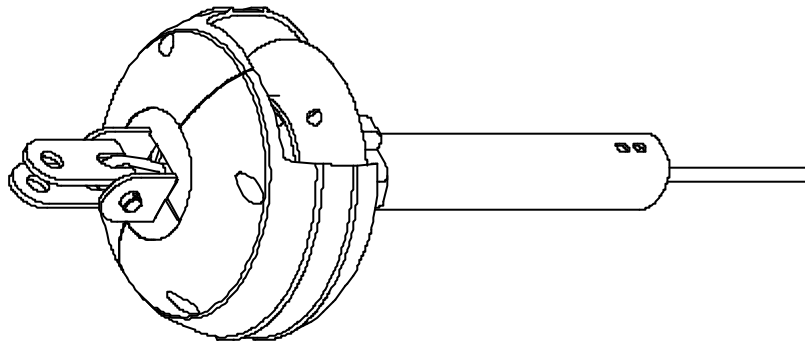

6B) FOR ASSEMBLY ON FORESTAY WITH TURNBUCKLE.

- When assembling on a forestay with turnbuckle, it is better to add a toggle.

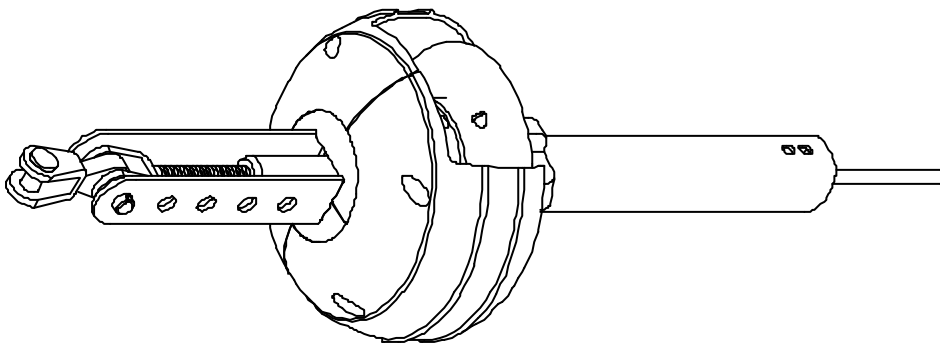

7- ASSEMBLY OF THE LOWER SPAR

-Fit the lower spar onto the forestay.

-Place a connecting stop, the aluminium stop-rotation connection and a blue connecting sleeve in the lower spar (align the holes in the lower spar connection with those on the spar itself).

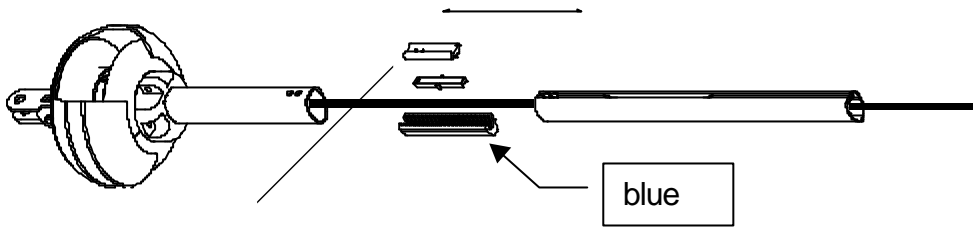

- Counterpierce the plastic connection with a drill bit $\varnothing 2.8$ and place a screw 3.9x15.9 (on the opposite side of the grooves, as this will prevent the three parts from moving within the spar)

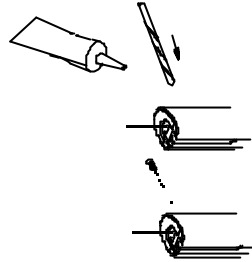

Stop-rotation connection

- Insert the spar into the drum tube by placing the two holes facing the holes of the stop-rotation connection.

- Place the small plastic tubes in the Chc M6x16 screws and screw them into the stop-rotation connection ; it is necessary to put mastic silicone in the screw holes to diminish the electrolytical couple stainless steel/aluminium.

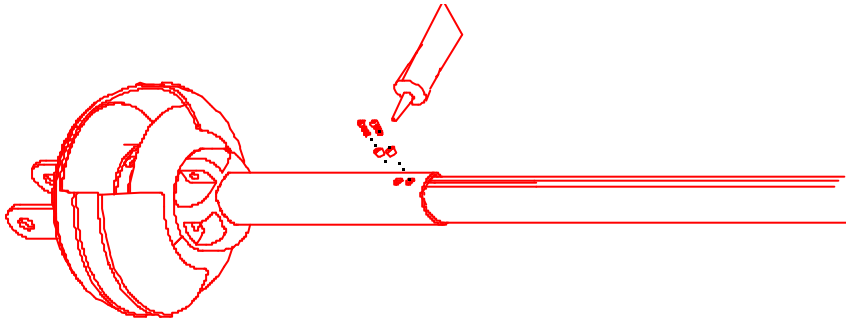

8 - ASSEMBLY OF INTERMEDIARY SPARS

- Insert a black connecting sleeve, a connecting stop and a stop-rotation connection at the other end of the lower spar.
- Put a screw $\text{Ø}3.9 \times 15.9$ in the hole the furthest away from the end (put mastic silicone under the head of the screws).
- Fit an aluminium intermediary spar on the connecting sleeve unit.

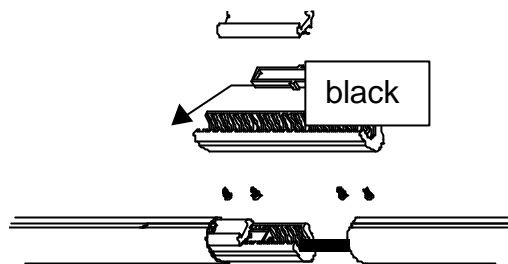

- Put a screw $\text{Ø}3.9 \times 15.9$, drill the other two holes with a drill bit, size $\text{Ø} 2.8$ mm

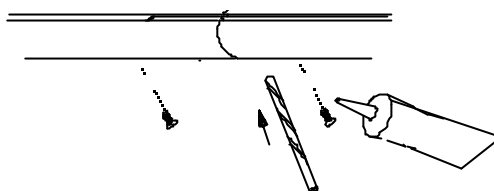

- Put screws $\text{Ø}3.9 \times 15.9$ and repeat the operation until the second last spar.

9 - ASSEMBLY OF LAST SPAR

- Put the last spar up to the top end of the second last spar without inserting it.
- Make a cross 10cm away approximately from the sleeve of the forestay.
- Cut the spar with a saw.
- Screw a connecting unit.
- Push in the last spar and fix it.

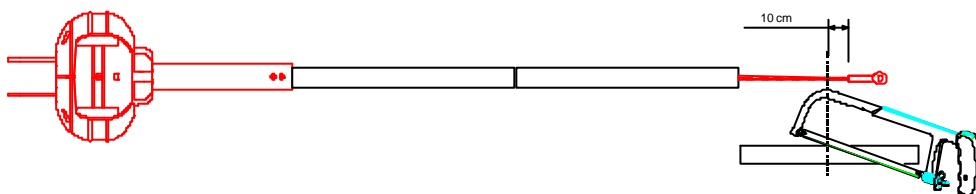

10 - INSTALLING THE SPAR END

- Fit the spar end onto the aluminium spar

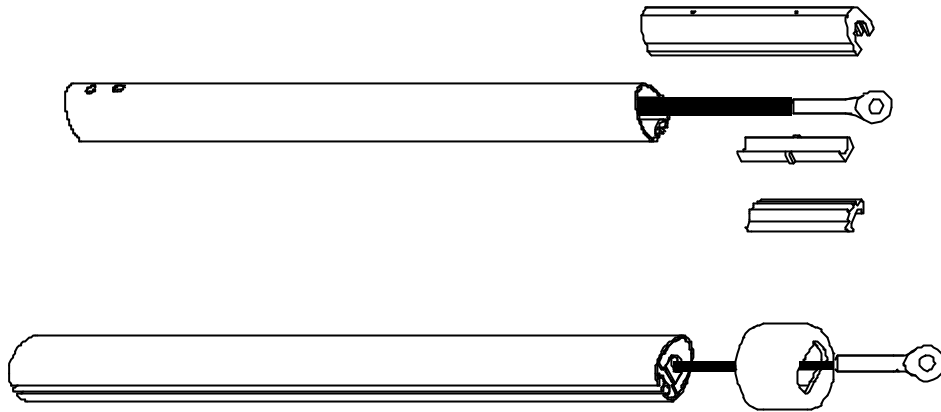

- Drill a hole with a drill bit, size $\text{Ø}4.2$ mm

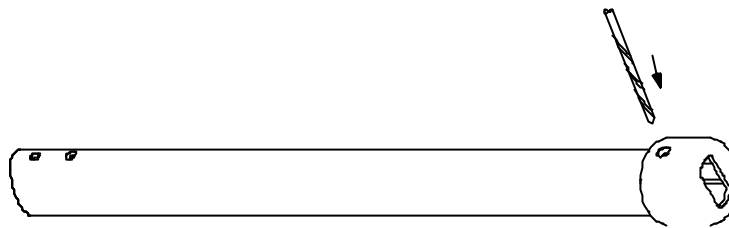

- Put some mastic in the screw hole

- Before putting in the screw, don't forget to insert the swivel!! (make sure the PLASTIMO logo is at the bottom; ensure the swivel slides properly along the length)

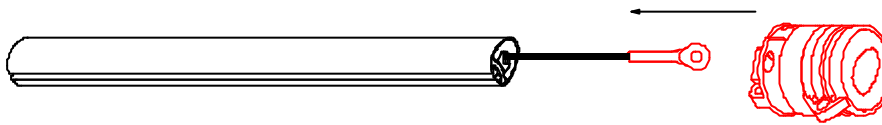

- Place the screw $\text{Ø}4.8 \times 12.7$

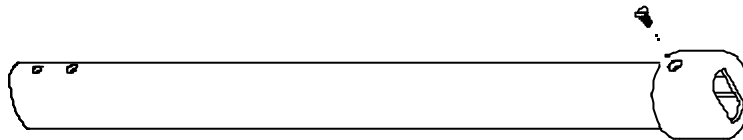

11 - INSTALLATION OF HALYARD DIVERTER (OPTION)

- Place the two half-clamps on the forestay and jot down the corresponding number.

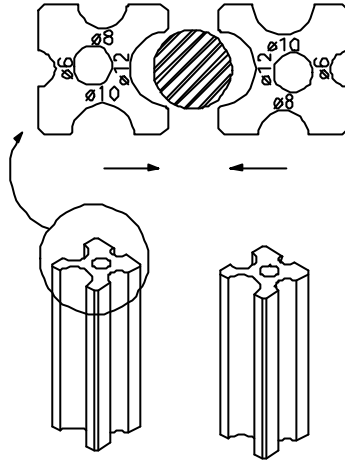

- Push the two half-clamps into the half-diverters taking into account the diameter you took down previously (see diagram).
- Screw the screws in place without tightening them : the final adjustment will be made on the masthead.
Caution : the two short screws should be placed at the front, ie. the opposite side to the sheave.
- Look carefully at the diagram showing the position of each part in order to have it clearly in mind once at the masthead. **Do not forget to pass the halyard behind the sheave.**

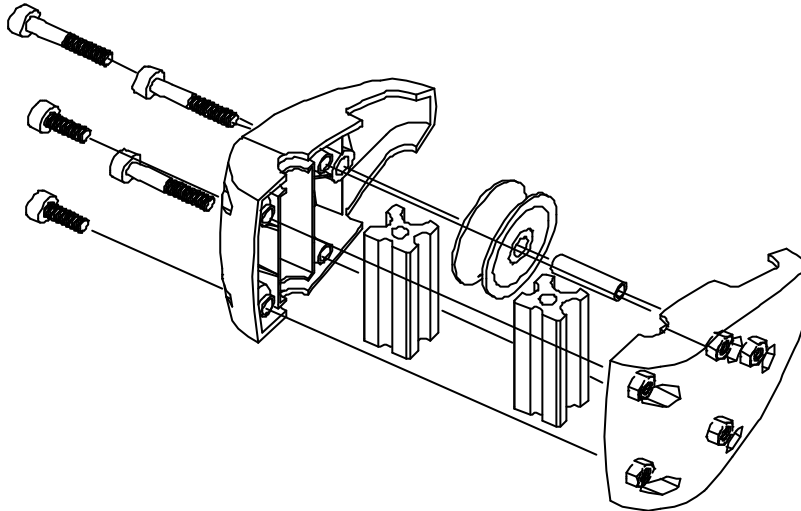

12 - INSTALLING THE REEFING SYSTEM

- Hoist the reefing system using a shackle under the forestay eye. (Do not use the swivel to hoist the reefing system to the masthead.)

CAUTION : You must reduce as much as possible the arrow of the reefing system when you are hoisting it.

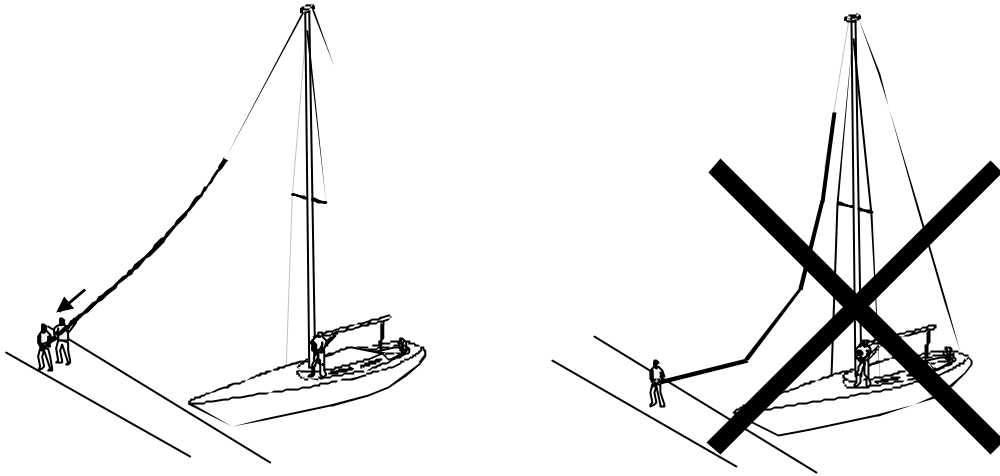

- Send a person up to the masthead.
- Assemble the upper part of the forestay.
- Fasten the unit starting with the upper part.

NOTE : If using a halyard diverter, fasten it now on the forestay without forgetting to put a halyard through the diverter and to tighten the latter.

- Fasten the lower part of the unit.

13 - INSTALLING THE DRUM REEFING LINE

- Use a pre-stretched reefing line (see optional extras in the Plastimo catalogue).
- Put the end of the reefing line through the hole in one of the half drums and make a knot, catching it at the top of the drum.

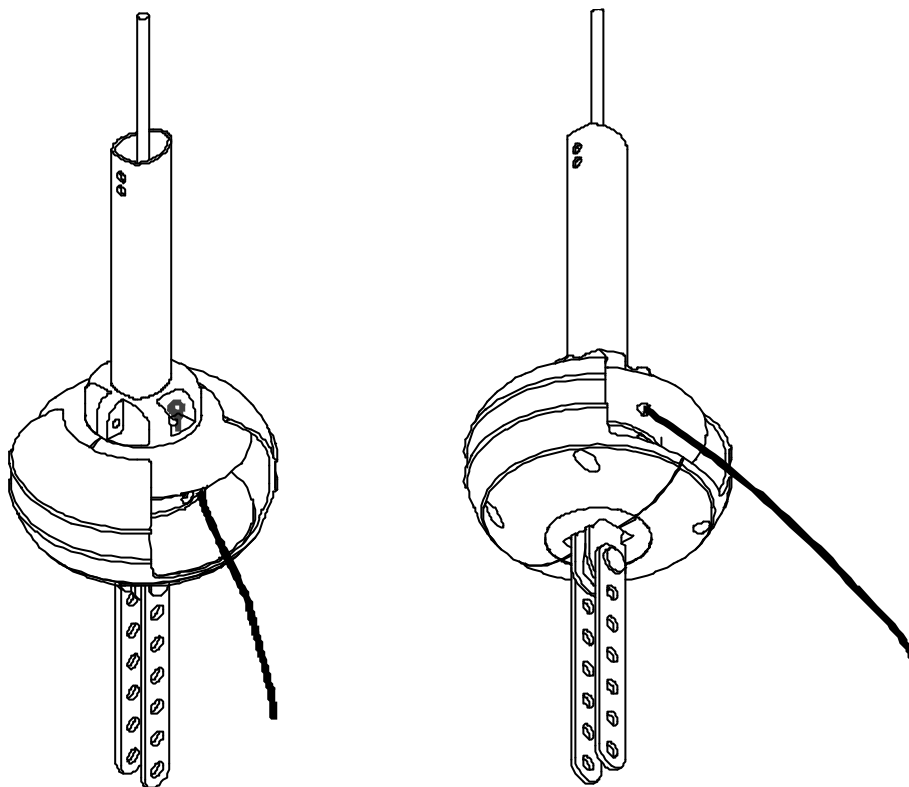

- Reposition the reefing line feeders until the correct angle has been reached.

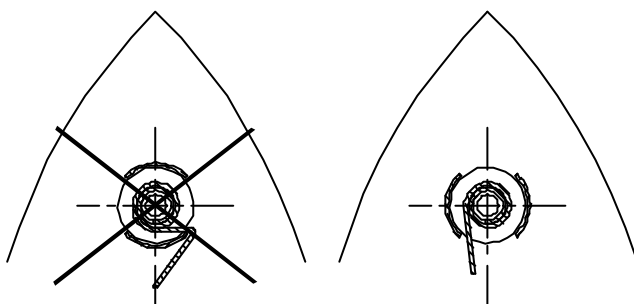

CAUTION: The first pulley of the reefing line must be at least 1 metre away from the drum in order to avoid line fouling when reefing.

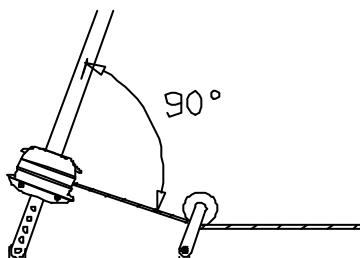

14 - WHEN USING AS HEADFOIL.

- Untighten the two screws which hold the reefing line feeders (1)
- Untighten the two screws which hold the half-drums (2)
- Make sure you do not lose the screws.

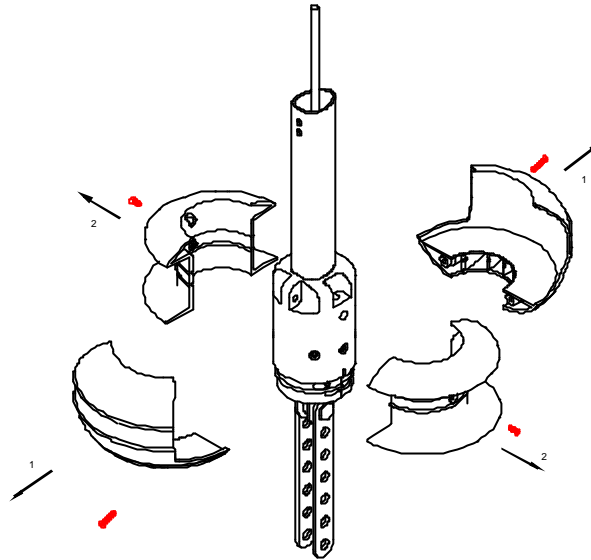

15 - FIXING THE BOLT ROP FEEDER

- Slide the feeder into the groove of the lower spar and adjust.
- Screw it on.

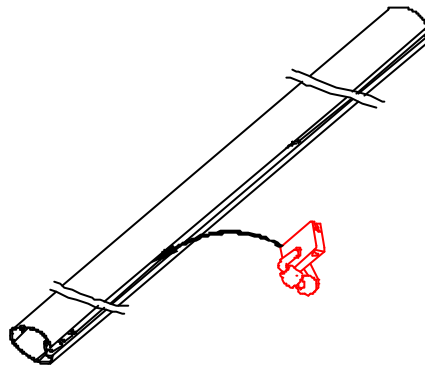

16 - INSTALLING THE SAIL

- Ensure unit rotates easily by turning it with 2 fingers only.
- Slide the halyard swivel up and down on all the spars in order to make sure no untightened screw or other item is in the way (attach a rope to the halyard swivel in order to slide it down again).
- Fit out the genoa and hoist it.

BE CAREFUL:

- Use a shackle to attach the halyard. If a snap hook is really necessary, make sure it doesn't rub against the top end stop, once the genoa has been hoisted.
- Use a 5 to 5.5 mm diameter luff tape.
- Once the sail is taut, haul on the reefing line in order to reef it round the spars.
- Double check that the direction of pull and the reefing line exit point are in the right position by reefing and releasing the genoa several times using the reefing line and the genoa sheet. Correct if necessary.

CAUTION: The genoa unfurls very easily. Care should be taken when feeding out the reefing line to ensure that fouling of the line does not occur.

You are now ready to sail.

Reefing line

The reefing line is the line that goes round the drum.
Use only pre-stretched lines in order to avoid elasticity.

Direction of furling for the genoa

Make sure the genoa is furled in the same direction as the strands of the forestay.

When not at sea

Urtighten the backstay to avoid leaving the mechanical components permanently taut.

Concerning the drum

When your genoa is entirely furled, enough reefing line must be left to go once round the drum, in order to avoid direct tension on the mechanical parts and on the knot on the reefing line.

Angle halyard/forestay

This angle must never exceed 20 - 25°, otherwise it will be impossible to either sweat up or furl the halyard.

With the pressure of the pull on the forestay, there is a risk of it getting very quickly unstranded with all the consequences this entails (dismasting...).

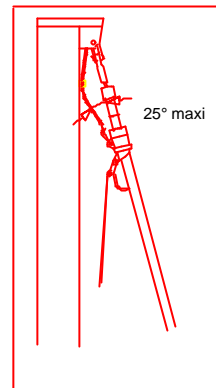

When at sea

Keep the tension on the forestay, furling will therefore be easier, the sail better furled and there will thus be no risk of the forestay losing its strands.

Sheeting the genoa

You must never sheet the genoa with the reefing line of the reefing system.

Reefing the genoa

When reefing the genoa, put a slight drag on it to prevent it from reefing too quickly.

To slow it down, turn the reefing line once around a winch and hold the genoa sheet in the one hand with the reefing line in the other in order to control speed of reefing.

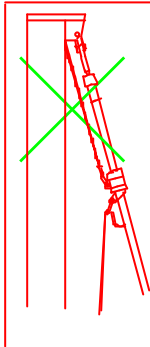
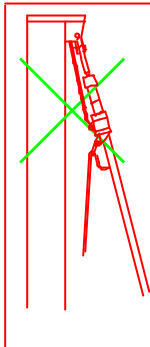
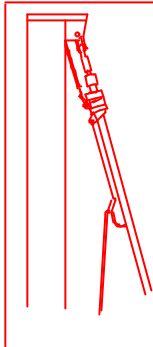
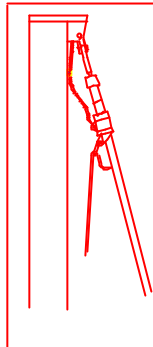
PROBLEM	CAUSES	REMEDIES
The halyard twists with the swivel	<ul style="list-style-type: none"> - Forestay not taut enough : - Genoa halyard not tight enough : - Genoa too short, swivel too low :  <ul style="list-style-type: none"> - Genoa halyard not far away enough from the forestay 	<ul style="list-style-type: none"> - Tighten the backstay - Stretch the genoa halyard - Use a strop  <ul style="list-style-type: none"> - Attach a fairlead on the mast or a diverter wheel on the forestay 
The halyard tends to twist around the spar when the genoa is being hoisted	<ul style="list-style-type: none"> - Your halyard is old and because of its stranded fibres, it twists around automatically : 	<ul style="list-style-type: none"> - Change the halyard
Fouling of reefing line	<ul style="list-style-type: none"> - Incorrect pull angle of reefing line : - Genoa released too fast during unfurling 	<ul style="list-style-type: none"> - Move the first sheave - Take care when unfurling genoa by turning the reefing line around a winch.
Difficulties in hoisting the genoa	<ul style="list-style-type: none"> - Sheave not functioning properly : - Halyard stuck : 	<ul style="list-style-type: none"> - Try with another halyard - Change boltrope (boltrope too thick)

- Wash the parts of the drum (without taking it off), once a year, in fresh water.
- No other kind of maintenance is required.

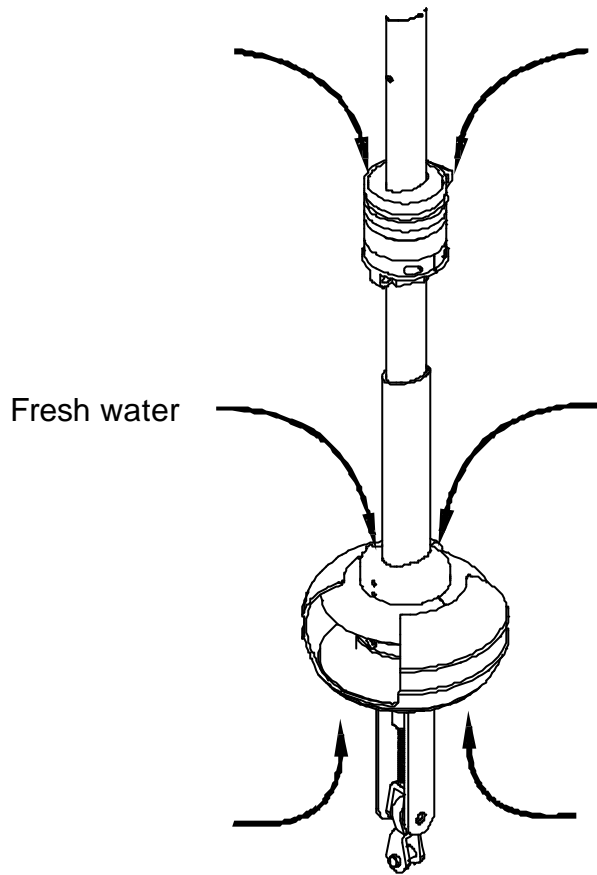

19A) HALYARD DIVERTER

If the angle between the halyard and the forestay is too small, there is a risk of the halyard getting twisted round with the halyard swivel when hoisting or unfurling the genoa.

If this happens, you can opt for one of the following two solutions :

19A-1) Halyard diverter

To install this kit, you need to dismantle the forestay or put it down when installing the jib reefing.

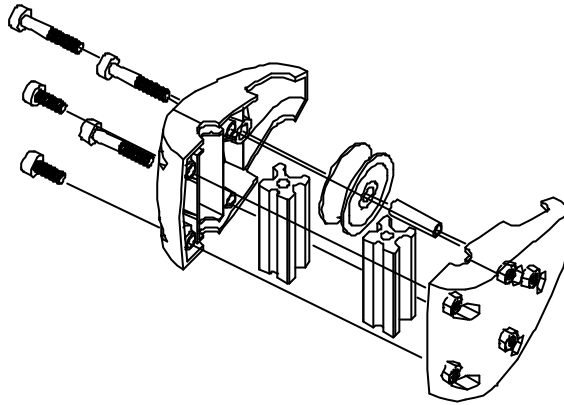

Reference : 18656

19A-2) Fairlead

To install the fairlead, you do not have to dismantle the forestay.



Reference : 25677

19B) TOGGLE

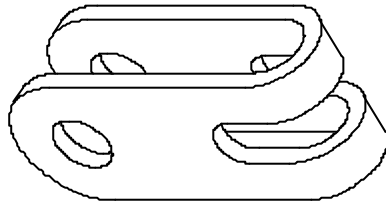

Reference : 30531

20 - SPARE PARTS

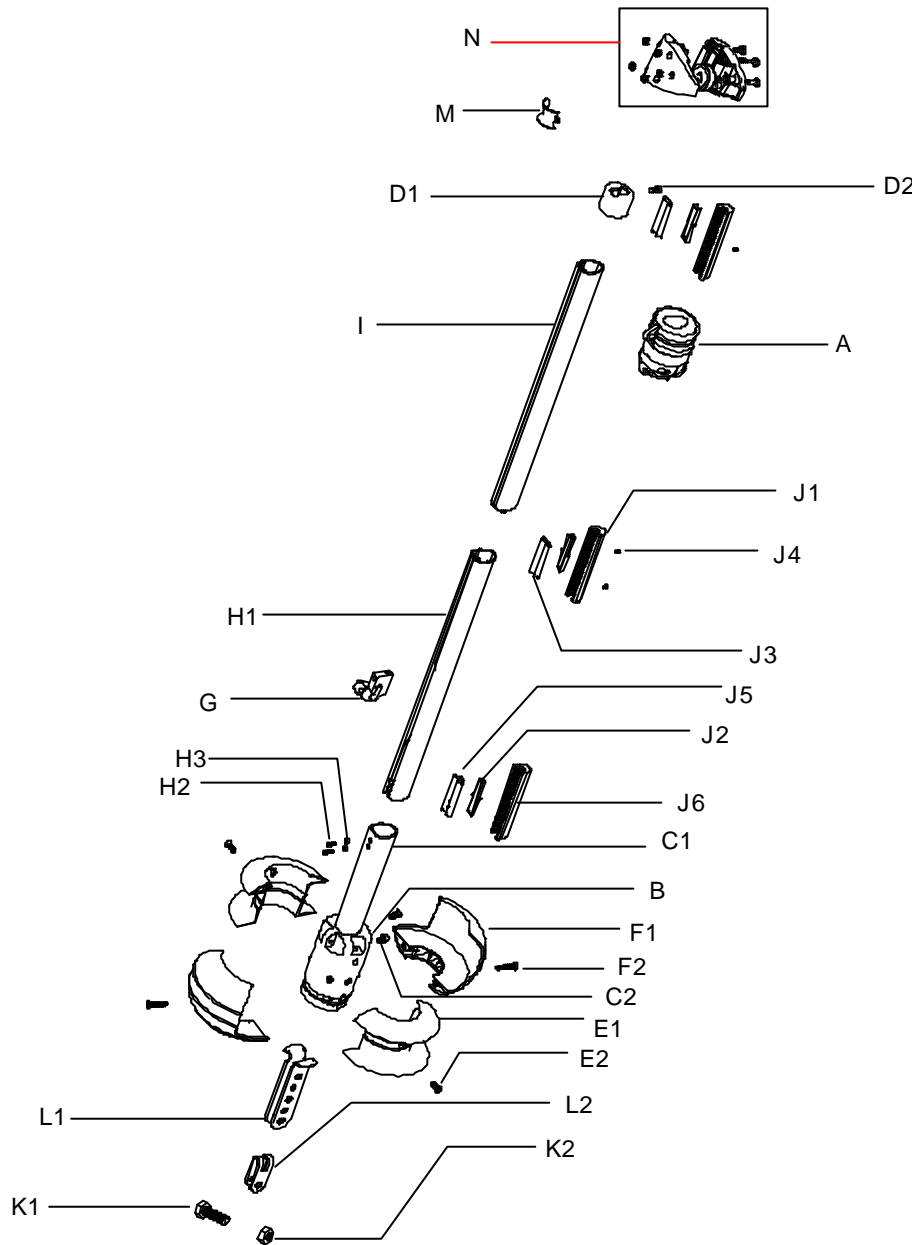

Rep	Reference	Designation	Quantity per 1012T	Quantity per 1213T
A	36887	Halyard swivel	1	1
B	31221	Assembled drum	1	1
C1	30522	Drum tube	1	1
C2	31036	Screw CHC M6x20 for drum tube	2	2
D1	30768	Top end stop	1	1
D2	25672	Screw TF Ø4.8x12.7 for spar fitting	1	1
E1	30527	Half drum	2	2
E2	14295	Screw TFHC M6x16 for half drum	2	2
F1	31039	Reefing line feeder	2	2
F2	14294	Screw TFHC M6x35 for reefing line feeder	2	2
G	25884	Bolt rope feeder	1	1
H1	30524	Aluminium lower drum spar L=2m	1	1
H2	22596	Screw CHC M6x16 for lower drum spar	2	2
H3	31035	Plastic tube Ø10x6 10mm thick for lower drum spar	2	2
I	30525	Aluminium standard spar L=2m	6	7
J1	14288	Connecting sleeve (black)	6	7
J2	22998	Connecting stop	8	9
J3	30526	Stop-rotation connection	7	8
J4	31533	Screw Ø3.9x15.9 spar connections	26	30
J5	30980	Lower spar connection	1	1
J6	24993	Connecting sleeve (blue)	2	2
K1	22855	Screw TH ø14x40 st. steel A4	1	
	22856	Screw TH ø16x45 st. steel A4		1
K2	22857	Nut ø14 st. steel A4	1	
	22858	Nut ø16 st. steel A4		1
L1	30529	Chainplate (200 mm)	2	2
	14276	Chainplate (233 mm)		2
L2	30531	Toggle	(1)	(1)à
M	25677	Fairlead	(1)	(1)
N	18656	Halyard diverter	(1)	(1)